

# FE-13 Component Description

## Manifold EI-Check



A UTC Fire & Security Company

Effective: April 2007  
K-96-8220

P/N: 877960

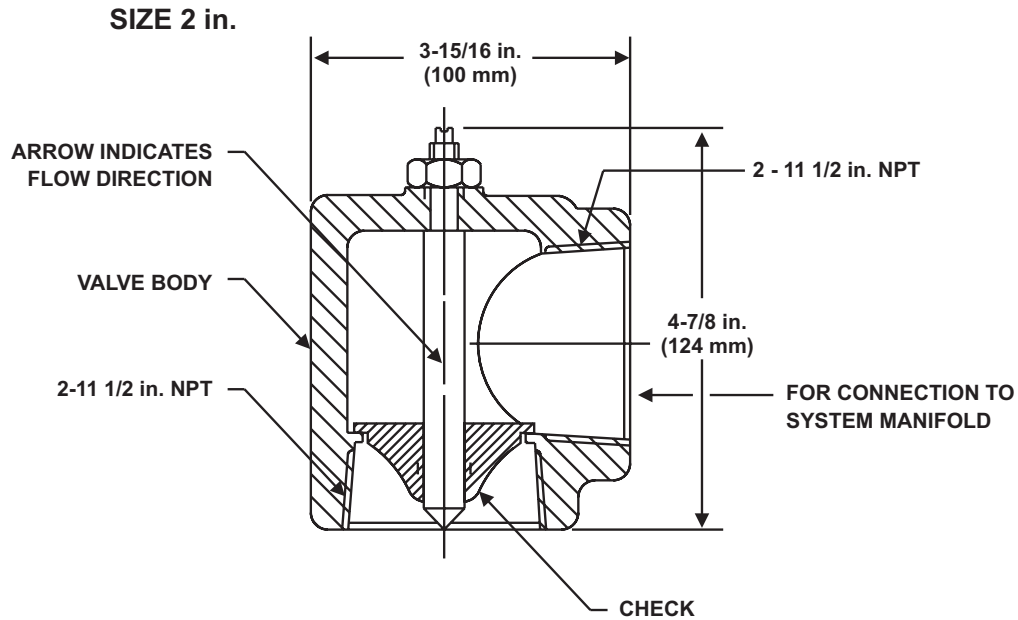

### MATERIAL:

VALVE BODY: ZINC PLATED STEEL

CHECK: STAINLESS STEEL

SEAT: NITRILE RUBBER

### NOTES:

1. EI-check is to be installed at system manifold in vertical direction as shown.
2. Use 2-inch x 1-1/2 inch hex bushing at inlet for attachment of flex hose.

This literature is provided for informational purposes only. KIDDE-FENWAL, INC. assumes no responsibility for the product's suitability for a particular application. The product must be properly applied to work correctly. If you need more information on this product, or if you have a particular problem or question, contact KIDDE-FENWAL, INC., Ashland, MA 01721. Telephone: (508) 881-2000.